

# Course Name: Solid State Physics (PHY503)

## Unit 1 :Crystal Structure

Dr Kamal Devlal

Department of Physics

Uttarakhand Open University, Haldwani

[kdeolal@uou.ac.in](mailto:kdeolal@uou.ac.in)

Mob. 8791477949

# Course outline

**1 Crystalline and amorphous solids**

**2 Crystal structure**

**( Lattice, Lattice translational vector, Primitive vector, Basis**

**3. Unit cell and primitive cell**

**4. Types of lattices (2D and 3D)**

**5. cubic crystal systems (sc, bcc, fcc)**

**6. Crystal symmetry and symmetry operation**

**7. Crystal Direction and Plane**

**8. Miller Indices**

**9. Some Crystal structures ( NaCl, CsCl, Diamond, ZnS, HCP)**

**10. Wigner Seitz cell**

**11. Quasi Crystal**

**12. Liquid Crystal**

# 1. Crystalline and Amorphous Solid:

## **Crystalline Solid:**

A crystalline solid is formed by regular repetition of its building blocks (atoms or molecule) in a three dimensional periodic array. The examples of crystals are table salt (NaCl), diamond, snowflakes, metals, ice, ceramics etc.

## **Amorphous solid:**

materials in which constituents (atoms or molecules) are not arranged in a regular manner over a long range. There is no periodicity in structure, if periodicity occurs, it must be over a short distance . The examples of crystalline solid are glass, plastic, rubber etc.

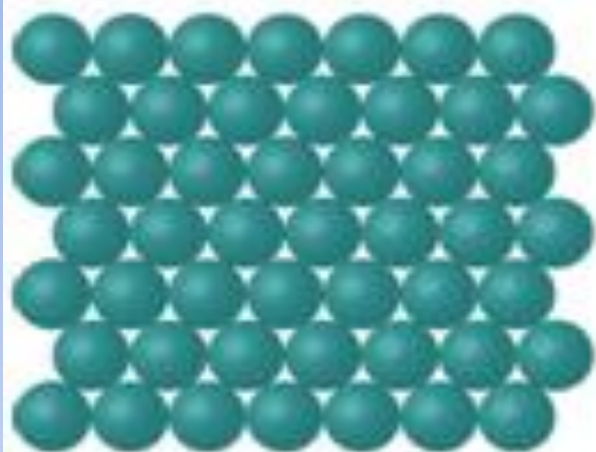

Crystalline

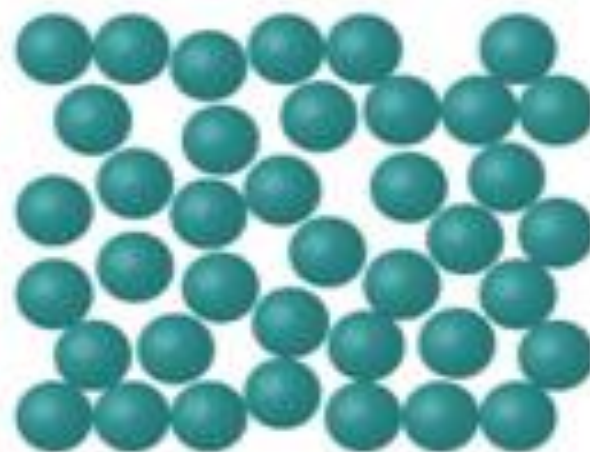

Amorphous

Figure 1.1: crystalline and amorphous solids

## 2. Crystal Structure

### Terms used in study of crystal structure

- **Lattice:** defined as a regular periodic array of point in space. Each point in a lattice has identical surrounding everywhere. Lattice is basically imaginary points on space with a periodic manner.
- **Basis:** atoms or molecules which are constituents of a crystal material. For example in NaCl crystal, NaCl molecule, group of one Na and one Cl atoms form basis.

# 2.1 Lattice points and basis

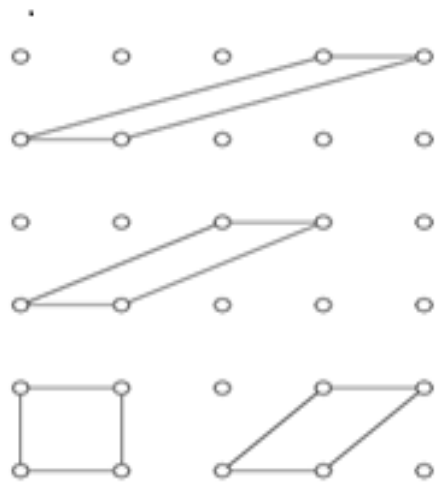

Figure 1.2 Lattice points in two dimensions

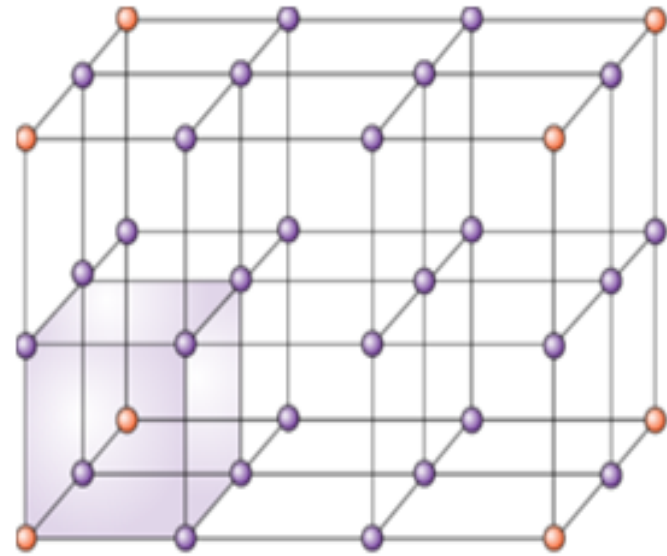

Figure 1.3 Lattice points in three dimensions

# Crystal structure = lattice + basis

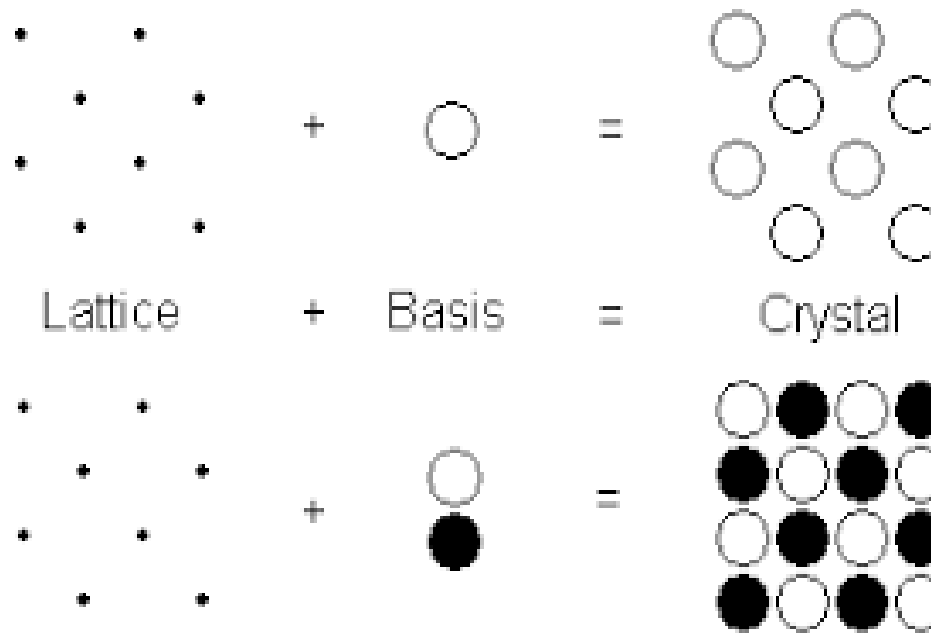

Figure 1.5: Crystal as combination of lattice and basis.

## 2.2. Lattice Translation Vectors

three fundamental vectors in such a way that all the lattice points in the crystal can be denoted.

$$r = n_1 a_1 + n_2 a_2 + n_3 a_3$$

Where  $n_1, n_2, n_3$  are integer numbers. And  $a_1, a_2, a_3$  are lattice translational vectors.

The lattice translation vector  $\mathbf{T}$  is a vector, which can connect any two lattice points, and  $\mathbf{T}$  can be given as

$$\mathbf{T} = n a_1 + l a_2 + m a_3$$



# Lattice Translation Vectors

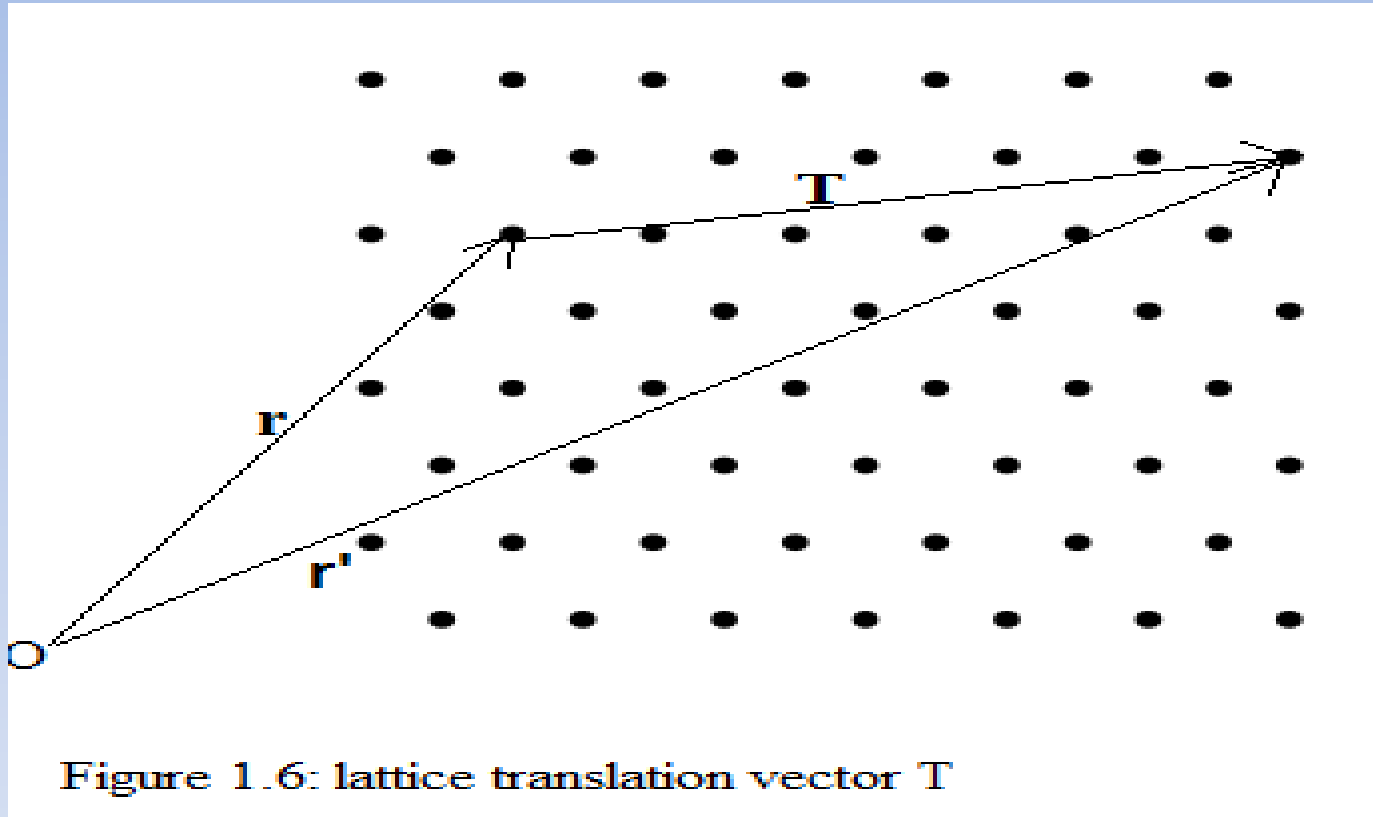

Figure 1.6: lattice translation vector  $T$

# 3. Unit cell and Primitive cell

- **Unit cell:** it is convenient to divide the crystal into small entities such small group of atoms or molecules is a well defined arrangement. These small cells are called unit cells. The unit cells are building blocks for construction of crystal structure.
- A unit cell can be completely described by three lattice vectors  $a_1, a_2, a_3$

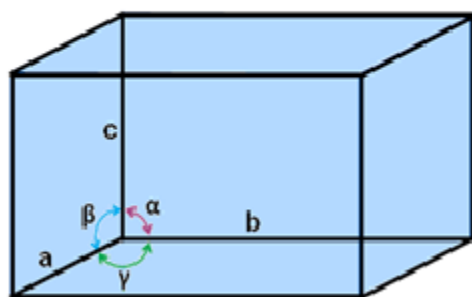

Figure 1.7: lattice parameter of unit cell

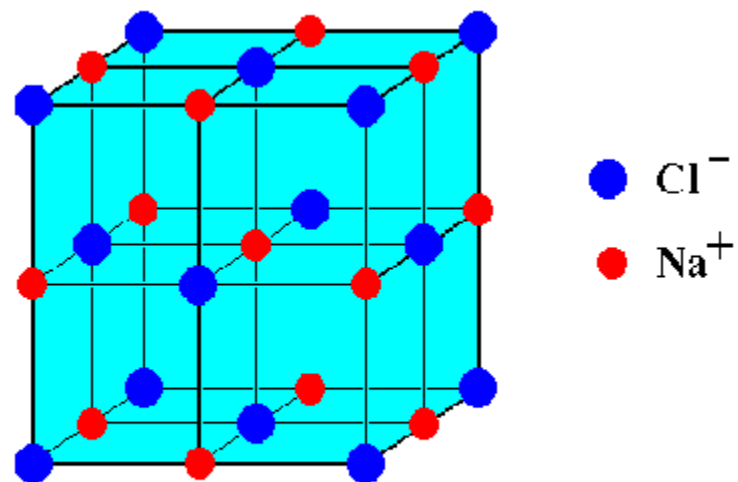

Figure 1.8 :Unit cell and primitive cell of NaCl

**Primitive Cell:** The smallest volume cell of crystal. We often use primitive lattice vectors to define the axis of crystal. translation vectors are primitive vectors if these vectors form three adjacent edges of parallelepiped of smallest volume

- **Difference between Unit Cell and Primitive Cell:**

the primitive cell always contains lattice points only at corners

## 4. Types of Crystal Lattice

**4.1. Two Dimensional Lattice Type:** consider two lattice vectors for defining any point. The simplest translational  $T$  can be given as

$$T = na_1 + ma_2$$

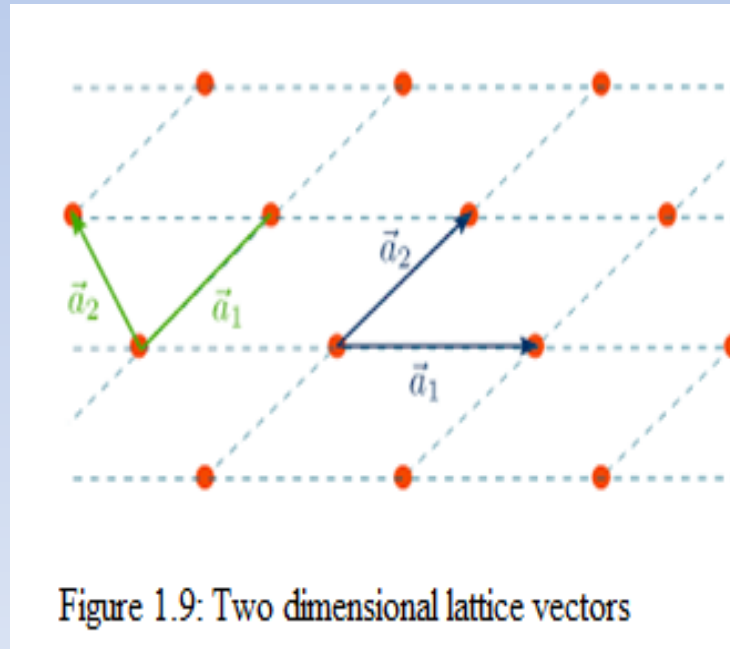

Figure 1.9: Two dimensional lattice vectors

# Five distinct type of lattice in two dimensions called Bravais lattice.

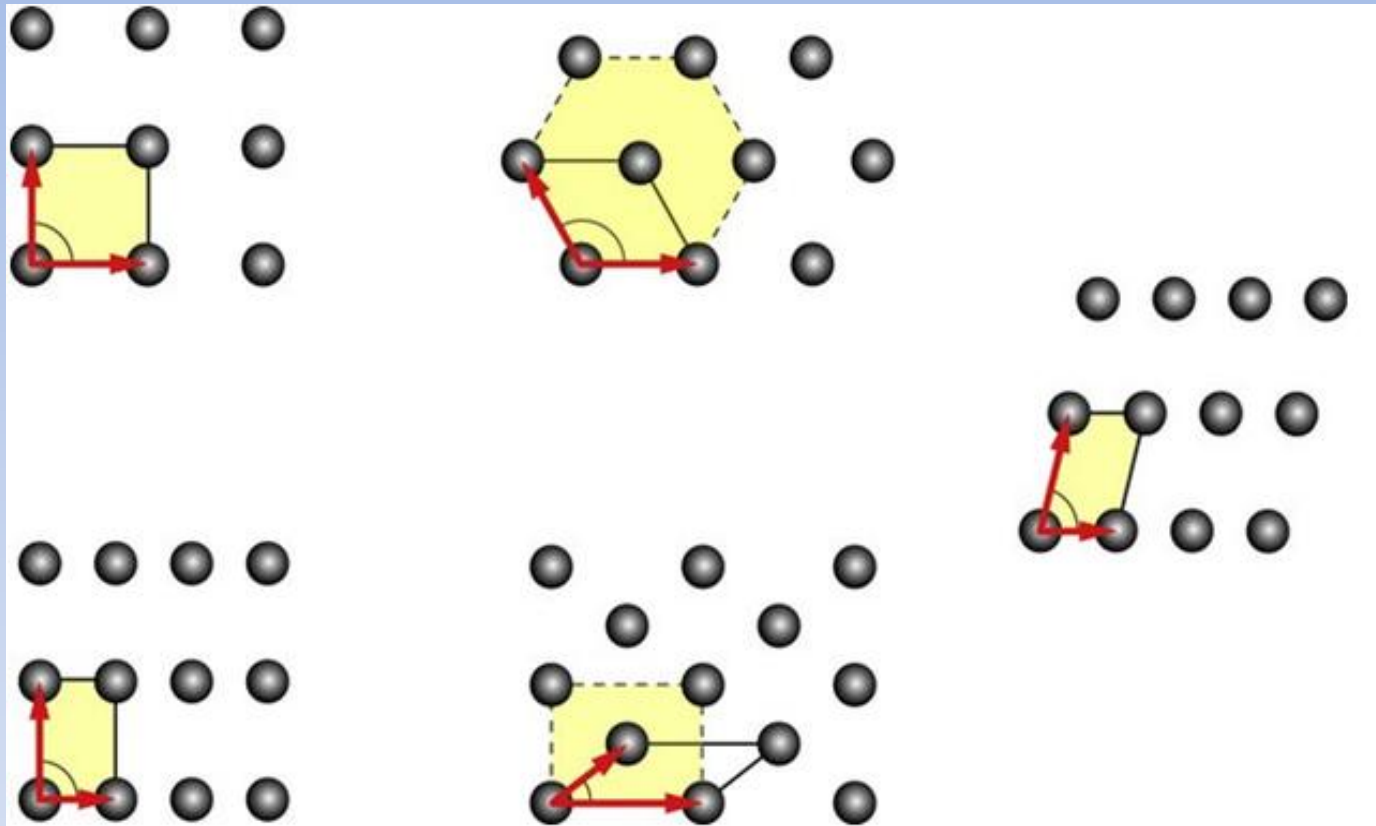

Figure 1.10: Five distinct types of Bravais lattice (square, Hexagonal, rectangular, centered rectangular, and oblique).

## 4.2. Three Dimensional Lattice Types

- crystal systems are divided into seven groups or seven types of crystal system based on the condition of lattice three vectors and three interfacial angles between them.
- seven types of crystal system which contain a total of 14 types of lattice
- named as cubic, tetragonal, orthorhombic, monoclinic, triclinic, trigonal (rhombohedral) and hexagonal

Crystal System	Number of Lattice	Lattice types	Restriction on lattice parameters	Lattice symbol	Examples
Cubic	3	Simple Cubic (sc) Body centered cubic (bcc) Face centered cubic (fcc)	$a_1 = a_2 = a_3$ $\alpha = \beta = \gamma = 90^\circ$	P I F	<i>Cu, Ag, Fe,</i> <i>NaCl</i>
Tetragonal	2	Simple tetragonal (st) Body centered tetragonal (bct)	$a_1 = a_2 \neq a_3$ $\alpha = \beta = \gamma = 90^\circ$	P I	<i><math>\beta</math>-Sn, TiO<sub>2</sub></i>
Orthorhombic	4	Simple Body centered Face centered End centered	$a_1 \neq a_2 \neq a_3$ $\alpha = \beta = \gamma = 90^\circ$	P I F C	<i>Ga, Fe<sub>3</sub>C</i>
Monoclinic	2	Simple End centered	$a_1 \neq a_2 \neq a_3$ $\alpha = \gamma = 90^\circ \neq \beta$	P C	
Triclinic	1	Simple	$a_1 \neq a_2 \neq a_3$ $\alpha \neq \beta \neq \gamma$	P	<i>Kr<sub>3</sub>Cr<sub>2</sub>O<sub>7</sub></i>
Trigonal (Rhombohedral)	1	Simple	$\alpha = \beta = \gamma < 120^\circ \neq 90^\circ$ $a_1 = a_2 = a_3$	P	<i>As, Bs</i>
Hexagonal	1	Simple	$\alpha = \beta = 90^\circ \neq \gamma = 120^\circ$ $a_1 = a_2 \neq a_3$	P	<i>Zn, Mg</i>



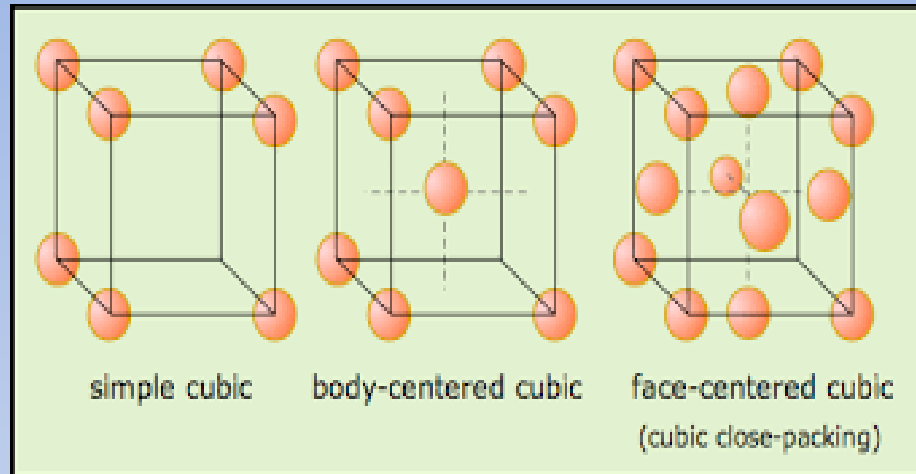

**Crystal Structures - Tetragonal**

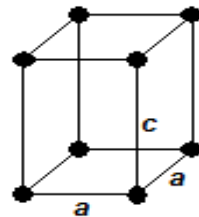

*Simple*

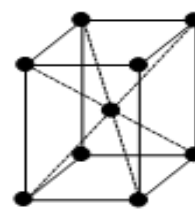

*Body-Centered*

# Orthorhombic Crystal System.

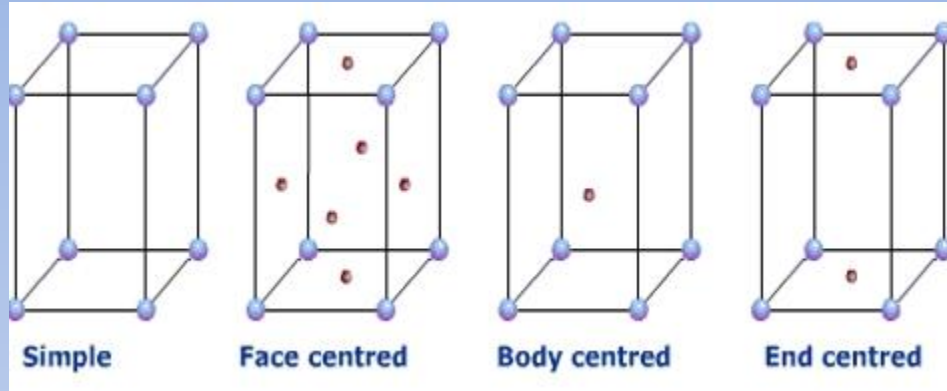

# Monoclinic Crystal System

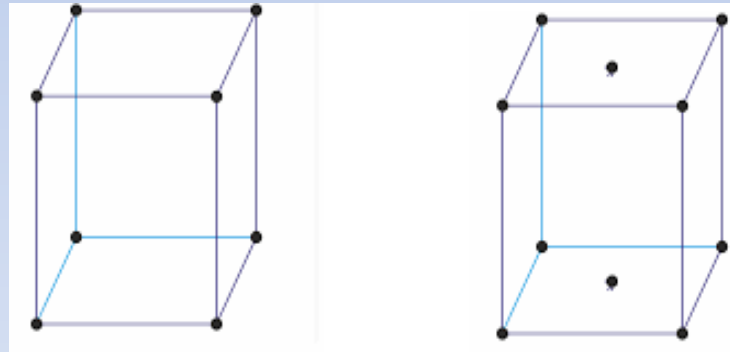

# Trigonal (Rhombohedral) Crystal

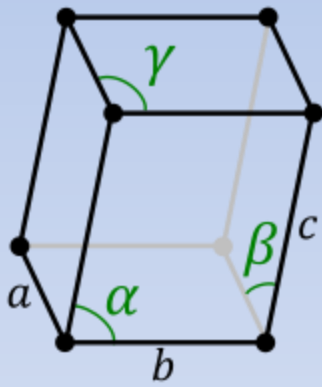

Triclinic Crystal System.

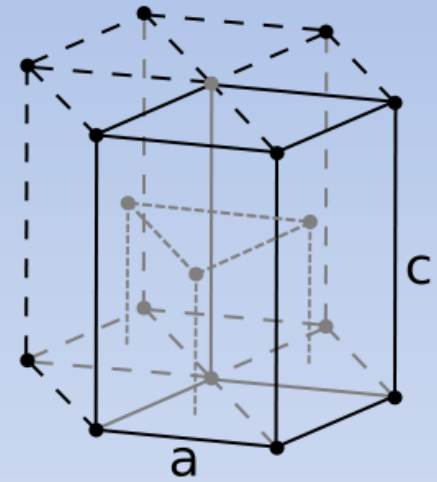
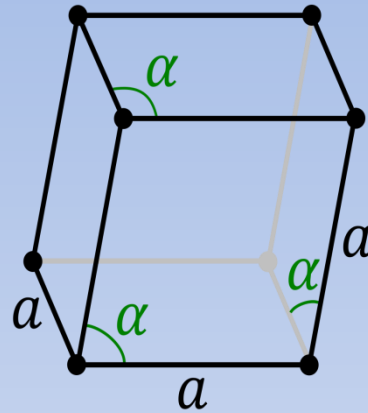

Hexagonal Crystal.

# 5. Cubic crystal system

- The simplest and easiest structure.
- Three types of possible crystal structure under this family named as simple cubic, body centered cubic and face centered cubic.

# 5.1 Simple cubic crystal (sc)

- Lattice points are arranged at each 8 corner of cube.
- At each corner of cube, an atom is shared by 8 nearby unit cells.
- one unit cell contains  $1/8 \times 8 = 1$  atoms.
- Each atom is surrounded by 6 nearest neighbors atoms. The number of nearest neighbors of a lattice point (or atom) in a crystal lattice is called coordinate number.
- Example Cu, Ag, Au are this types of structure.

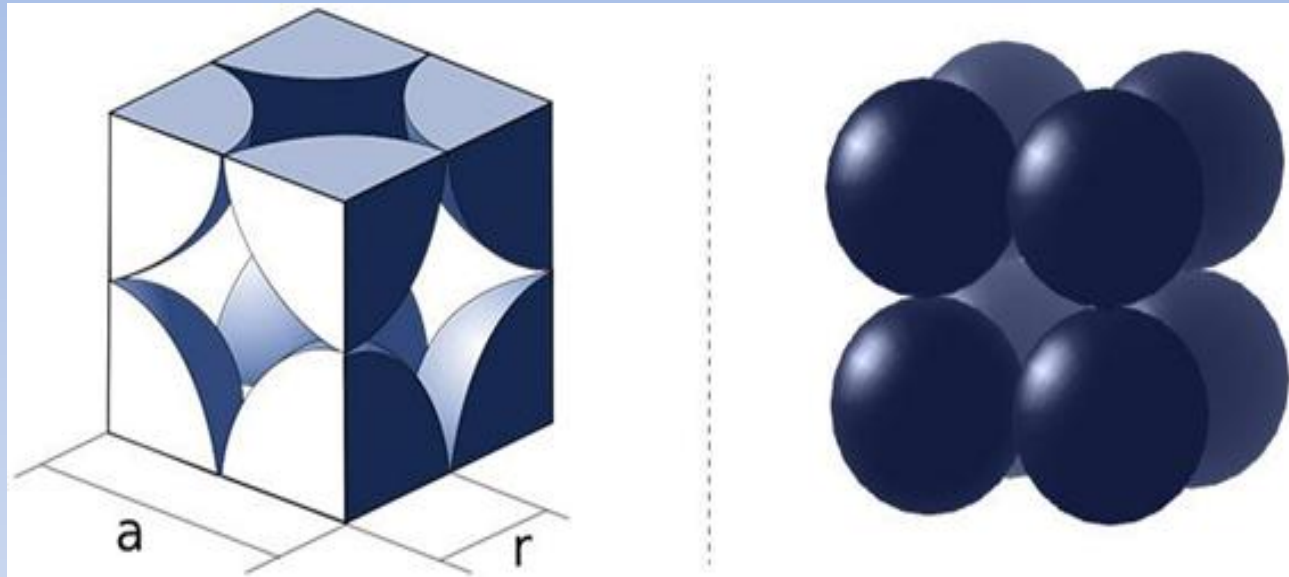

Figure 1.12: Cubic side length  $a$  and atomic radius  $r$  of simple cubic structure.

# Parameters of SC

*Nearest neighbour distance =  $2r$*

*Lattice constant  $a = 2r$*

*Coordinate number  $CN = 6$*

*Number of atoms per unit cell =  $\frac{1}{8} \times 6 = 1$*

*Volume of unit cell ( $V$ ) =  $a^3$*

*Volume of atom inside the unit cell ( $v$ ) =  $1 \times \frac{4}{3}\pi r^3 = \frac{4}{3}\pi r^3$*

$$PF = \frac{\text{volume of atoms in unit cell}}{\text{volume of unit cell}}$$

*Packing fraction (PF) =  $\frac{v}{V} = \frac{\frac{4}{3}\pi r^3}{a^3} = \frac{1}{6}\pi = 0.52$*

## 5.2 Body centered cubic (bcc)

- In this case of cubic crystal, one atom is arranged inside the cube additional to eight atoms at eight corners this structure
- one atom is inside the unit cell entirely, and eight corners of lattice cube share  $1/8$  part of each atoms. Therefore the number of atoms in a bcc unit cell  $=1+1/8=2$ .
- Many metals a like Li, Na, K, Cr exhibit bcc



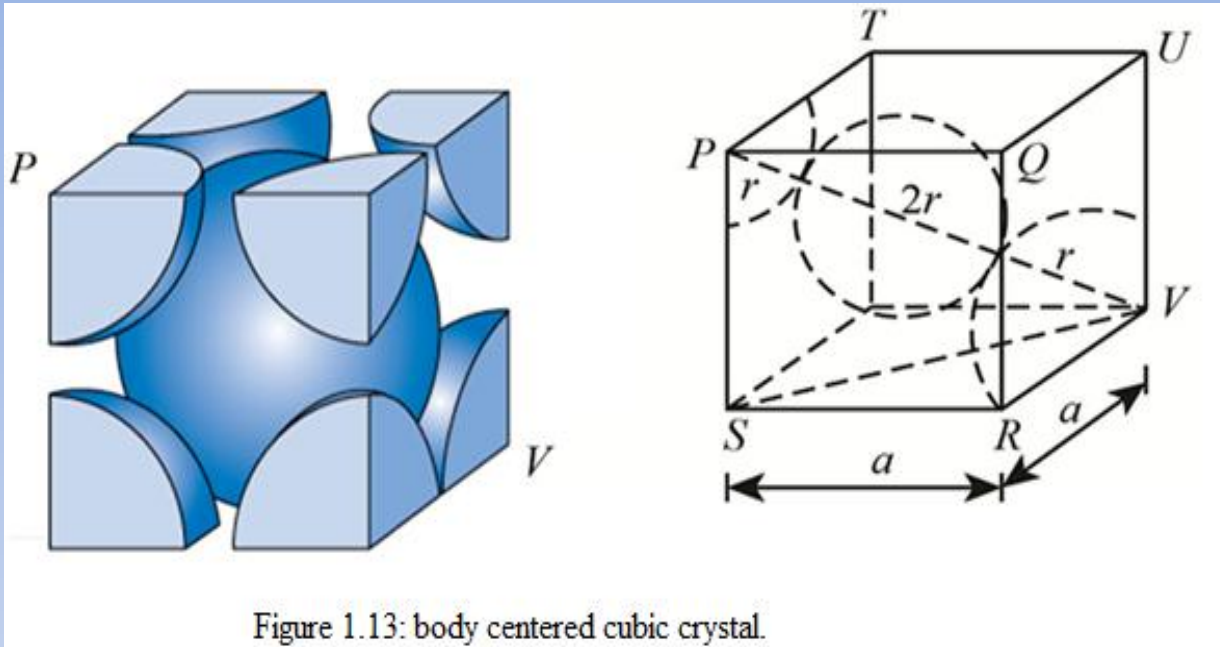

Figure 1.13: body centered cubic crystal.

- In figure

$$SV^2 = SR^2 + RV^2 = a^2 + a^2 = 2a^2$$

$$PV^2 = SV^2 + PS^2 = 2a^2 + a^2 = 3a^2$$

$$4r^2 = 3a^2 \quad \text{or} \quad a = \frac{4}{\sqrt{3}}r$$

# Parameters of bc crystal

$$\text{Lattice constant } a = \frac{4}{\sqrt{3}}r$$

$$\text{Nearest neighbour distance} = \frac{a}{2\sqrt{3}} = 0.866a$$

$$\text{Coordinate number } CN = 8$$

$$\text{Number of atoms per unit cell} = 1 + \frac{1}{8} \times 6 = 2$$

$$\text{Volume of unit cell } (V) = a^3$$

$$\text{Volume of atom inside the unit cell } (v) = 2 \times \frac{4}{3}\pi r^3 = \frac{8}{3}\pi r^3$$

$$\text{Packing fraction } (PF) = \frac{v}{V} = \frac{\frac{8}{3}\pi r^3}{a^3} = \frac{\sqrt{3}}{8}\pi = 0.68$$

## 5.3 Face centered cubic crystal

- 8 atoms are arranged at eight corners of the cubic lattice and 6 atoms are arranged at the centre of eight faces of cube
- Each atom of 8 corners is shared by 8 neighbor unit cells therefore one corner of cube share  $1/8$  atom; each atom at the faces of cube is shared by 2 unit cell and each face shared  $1/2$  atom and total 6 faces share  $6 \times 1/2 = 3$  atoms. Therefore net atoms inside a unit cell is equal to  $1/8 \times 8 + 1/2 \times 6 = 4$ .
- coordinate number of fcc crystal is 12.
- example of fcc Crystal are Al, Cu, Au, Ag etc.

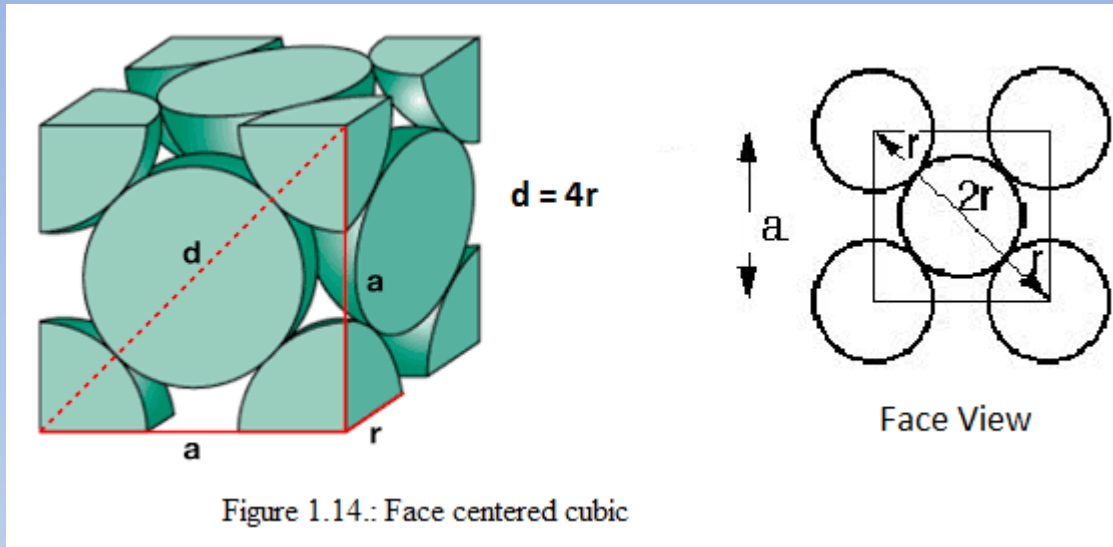

Figure 1.14.: Face centered cubic

$$(4r)^2 = a^2 + a^2 = 2a^2$$

$$16r^2 = 2a^2 \text{ or } a = \frac{4}{\sqrt{2}}r$$

Thus we can summarize:

$$\text{Nearest neighbour distance} = \frac{a}{\sqrt{2}}$$

$$\text{Lattice constant } a = \frac{4}{\sqrt{2}}r$$

$$\text{Coordinate number } CN = 12$$

$$\text{Number of atoms per unit cell} = \frac{1}{8} \times 8 + \frac{1}{2} \times 6 = 4$$

$$\text{Volume of unit cell } (V) = a^3$$

$$\text{Volume of atom inside the unit cell } (v) = 4 \times \frac{4}{3}\pi r^3 = \frac{16}{3}\pi r^3$$

$$\text{Packing fraction (PF)} = \frac{v}{V} = \frac{\frac{16}{3}\pi r^3}{a^3} = \frac{\pi}{3\sqrt{2}} = 0.74$$

## characteristics of cubic crystal

	Parameters	Simple Cubic	Body centered	Face centered
1	Lattice constant (a)	$a = 2r$	$a = \frac{4}{\sqrt{3}}r$	$a = \frac{4}{\sqrt{2}}r$
2	Volume of unit cell (V)	$a^3$	$a^3$	$a^3$
3	Number of lattice point (atom) per unit cell	1	2	4
4	Volume of primitive cell	$a^3$	$a^3/2$	$a^3/4$
5	Coordinate number (Number of nearest neighbors)	6	8	12
6	nearest neighbors distance	$a$	$\frac{\sqrt{3}}{2}a$	$\frac{1}{\sqrt{2}}a$
7	Packing fraction (PF)	$\frac{\pi}{6} = 0.52$	$\frac{\sqrt{3}\pi}{8} = 0.68$	$\frac{\pi}{3\sqrt{2}} = 0.74$

# 6. Symmetry and Symmetry Operations

- Crystal symmetry describes the similarity in the lattice points and environment throughout the Crystal
- symmetry operation is that which transform the Crystal to itself. Simply a symmetry operation interchanges the position of atoms which results the same appearance of crystal
- The symmetry operations are translation, rotation, reflection and inversion.
- Symmetry operations performed about a point or a line are called point group symmetry operations.
- symmetry operations perform by translation vectors are called space symmetry operations.
- There are total 230 space groups of entire crystal system and 32 point group which describe all symmetry operation about a point in space with does not move during operation

## (i) Translation Symmetry:

A lattice point under a lattice translation operation performed it gives another point which is exactly identical to initial point .

## (ii) Rotational Symmetry:

- If a crystal is rotated through a point by an angle  $\Theta$ , it transform the lattice to another lattice which is again itself in appearance.
- For simplest example is the crystal lattice is rotated by an angle  $\Theta$  is  $360^\circ$  its lattice arrangement remains same.
- Possible value of n are 1,2,3,4,6 only. multiplicity of rotational axis. Lattice can be found as one, two, three, four and six fold rotation about an axis which carries the lattice to itself.  $n=5,7,9$  not possible and lattice cannot transform into itself under such rotation thus 5,7,9 fold symmetry are not possible.

### **(iii) Reflection:**

If the lattice have a plane or line in two dimensional which divide the lattice into two halves which are mirror image of each other then this is called reflection symmetry such a plane is symbolically represented by letter small m.

### **(iv) Inversion:**

Inversion is a symmetry operation which is applicable in three dimensional lattice structure only. In this symmetry if we consider a point as centre of symmetry, and locate all points by lattice vector  $r$  then  $-r$  (inversion of sign) give the same lattice. The centre of inversion of lattice is denoted by symbol  $\bar{1}$  and read as one bar.



# 7. Crystal Direction and Plane

- it is necessary to locate the directions and planes for its analysis. In a crystal lattice the directions are given by the coordinates of first whole number point.

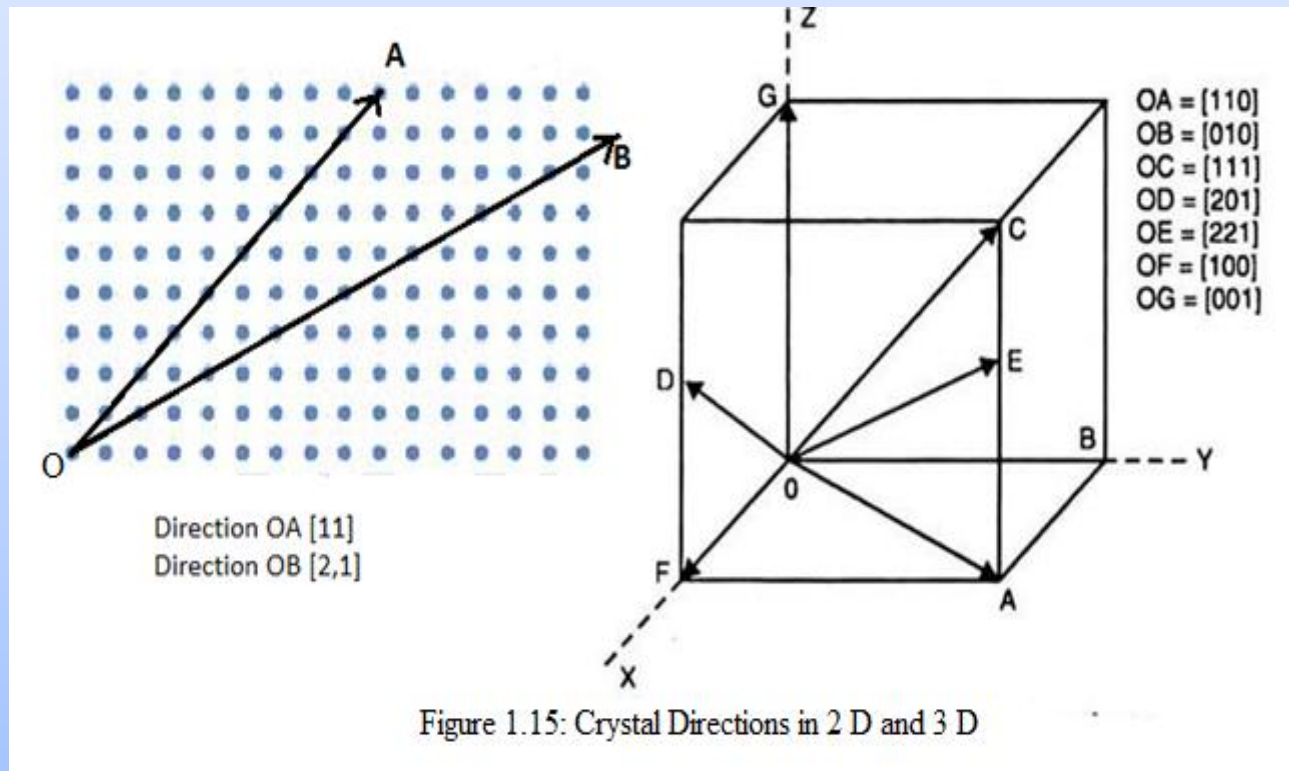

# 8. Miller Indices

- Crystal is made up an aggregate of a large number of parallel equidistance planes.
- The orientation of the planes are first defined by Miller, and known as Miller Indices.
- Miller indices represent the set of parallel planes. Miller Indices of a plane is obtained by following 3 steps:
  - (1) Find out the Intercepts of plane on the three crystal axis  $x$ ,  $y$ ,  $z$ .
  - (2) Take reciprocals of these intercepts
  - (3) Find out simplest ratio in integer number.

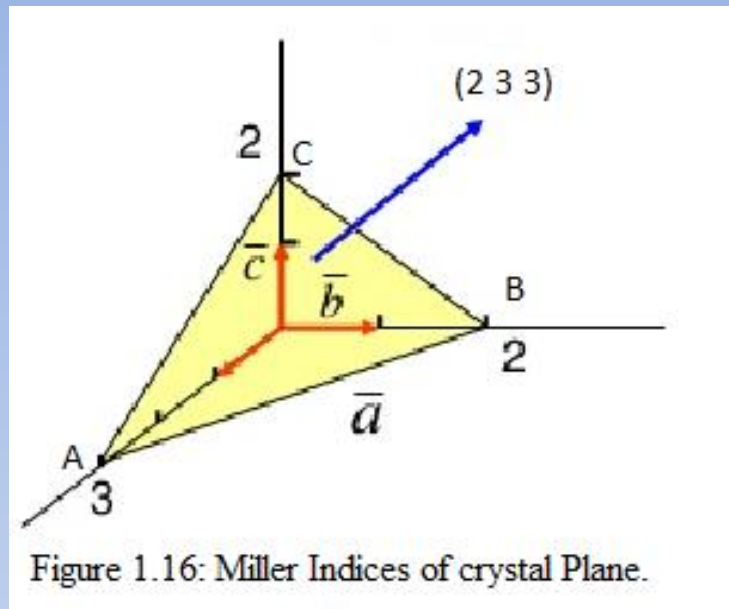

- (1) Intercepts of plane on the three crystal axis x, y, z are 3, 2, 2.
- (2) Reciprocals of these intercepts are  $1/3$  ,  $1/2$  ,  $1/2$
- (3) Simplest ratio of reciprocals in integer number are 2, 3, 3
- Thus Miller indices (2 3 3)
- Denoted by (h k l)
- A family of planes of a particular type of is presented by enclosing Miller Indices into a {} brass. For example the cube faces of a cubic crystal (100) (010) (001) (00) (00) (00) represented by family {100}

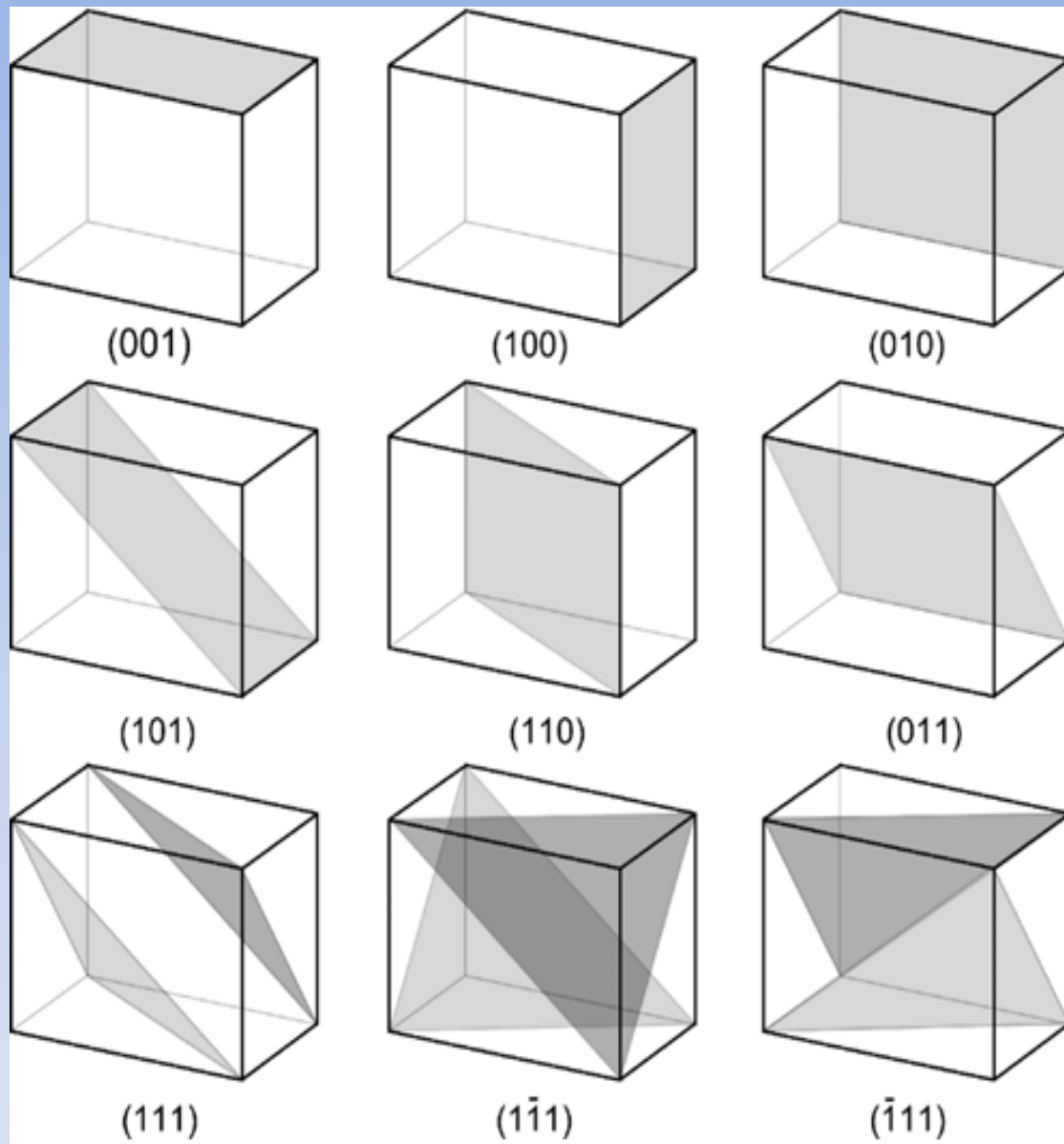

Figure 1.17 Miller indices of different planes of a cubic crystal family  $\{100\}$ .

## 9. Inter planer Spacing:

Crystal can be considered as arrangement of equidistance planes on which the lattice points.

Interspacing distance (separation) between two planes can be calculated and significant parameter in study of crystal diffraction.

Consider a set of parallel planes with indices (h k l) and among these planes, one plane is passing through origin O.

The next plane lies just parallel to first plane and gives intercepts  $a/h$ ,  $b/k$ ,  $c/l$  on x, y, z axis.

a, b, c are lattice vectors of a crystal. ABC is plane which intercepts x, y, z axis at points A, B, C respectively.

If we draw a perpendicular ON from O to plane ABC then  $ON=d$ .

Let us consider perpendicular ON makes angle  $\alpha'$ ,  $\beta'$ ,  $\gamma'$  with x, y, z axis respectively then we can consider a OAN as shown

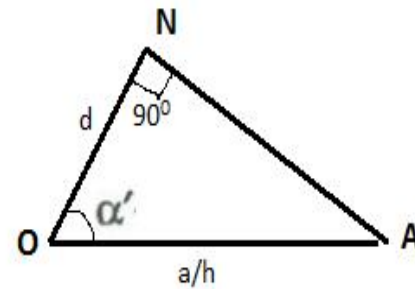
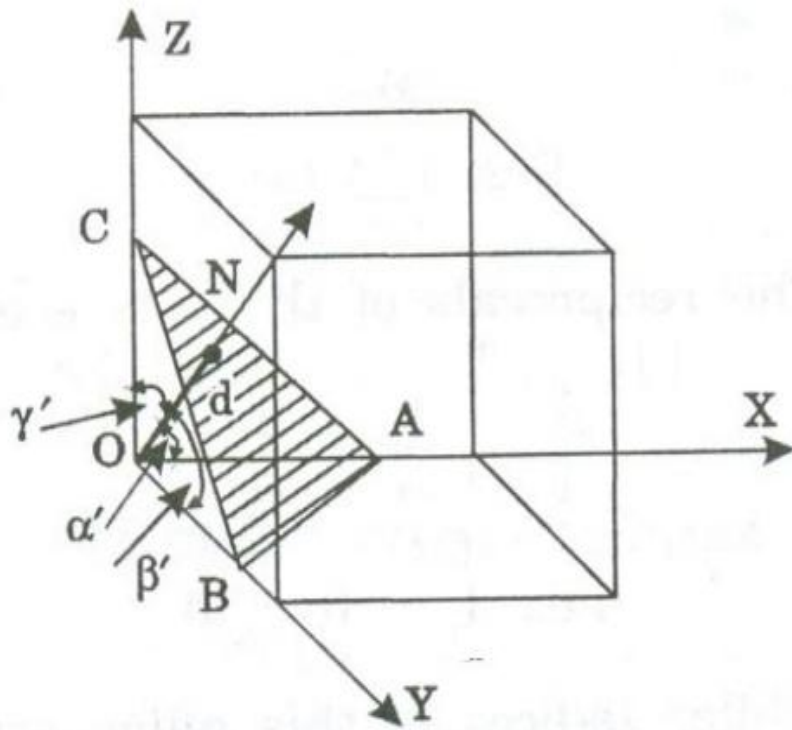

**Fig: 1.18 Separation between Lattice Planes in a Crystal**

$$\cos \alpha' = \frac{ON}{AO} = \frac{d}{a/h} = \frac{hd}{a}$$

$$\cos \beta' = \frac{ON}{BO} = \frac{d}{b/k} = \frac{kd}{b}$$

$$\cos \gamma' = \frac{ON}{CO} = \frac{d}{c/l} = \frac{ld}{c}$$

According to cosine law

$$\cos^2 \alpha' + \cos^2 \beta' + \cos^2 \gamma' = 1$$

$$\left(\frac{hd}{a}\right)^2 + \left(\frac{kd}{b}\right)^2 + \left(\frac{ld}{c}\right)^2 = 1$$

$$d = \frac{1}{\sqrt{\left(\frac{h}{a}\right)^2 + \left(\frac{k}{b}\right)^2 + \left(\frac{l}{c}\right)^2}}$$

## 10. Some Important Crystal Structure

For general understanding we can discuss simple crystal like sodium chloride (NaCl), cesium chloride (CeCl), hexagonal close packed (hcp), Diamond, zinc sulfide (ZnS), perovskite etc.

### Classification of Crystal Structure:

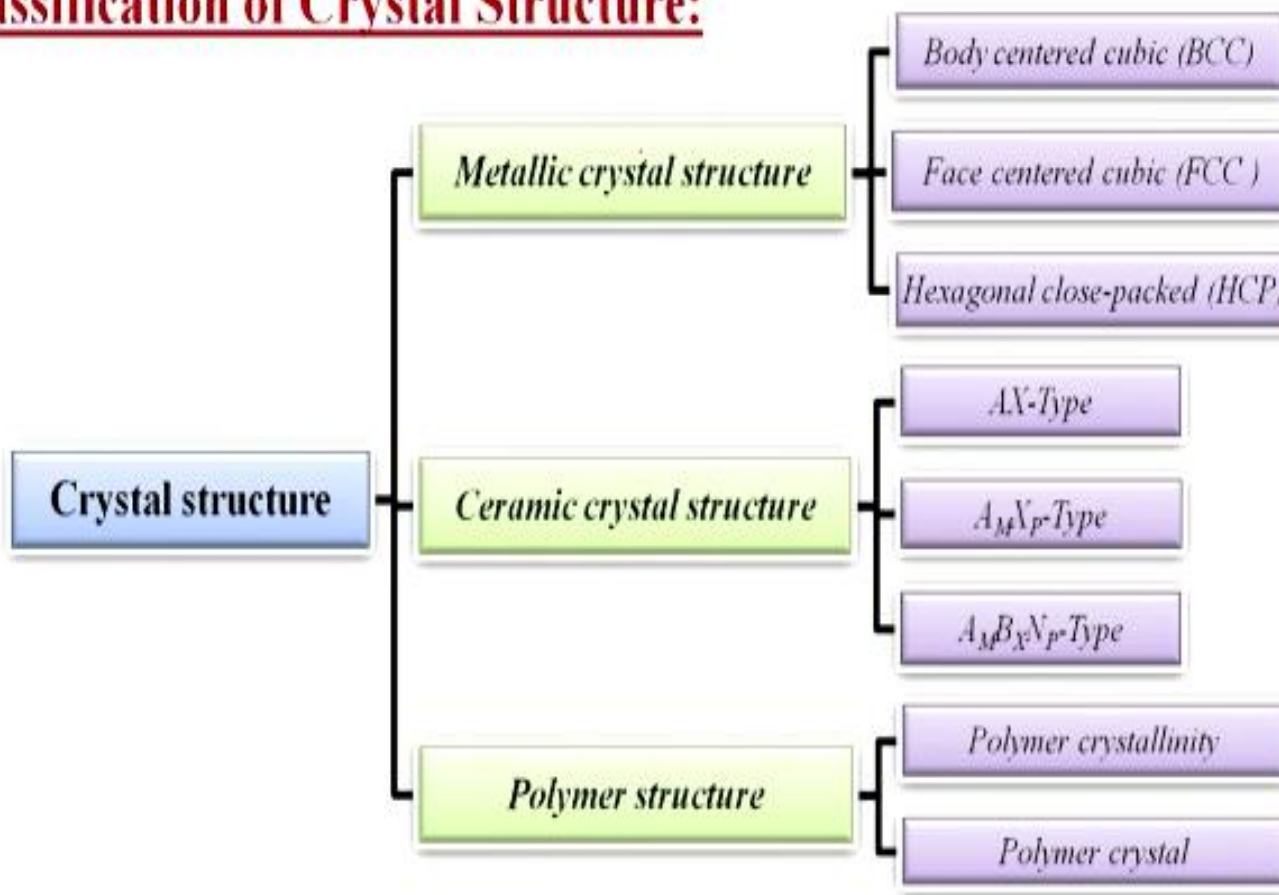

metallic crystal structure, we can find three types of structure, one is called the bcc (body centered cubic), then fcc (face centered cubic), and last one is the hcp (hexagonal closed packed) structure

- ceramics are compounds between metallic and non-metallic elements, they have interatomic bonds either totally ionic or with covalent characteristics, many ceramics have a combination of these two bonding types. AX (cations and anions are represented by A and X) structure is sodium chloride (NaCl) .  $A_M X_P$  where M and P not is equal to 1, so for examples  $CaF_2$  , fluorite. YThird type  $A_M B_X N_P$ , so for example  $BaTiO_3$
- Perovskite materials nowadays it is been widely used for the solar cells, generally the structure type is  $ABX_3$  like  $BiTiO_3$ ,  $SrZrO_3$ ,  $SrSnO_3$



# 10.1 Sodium Chloride (NaCl) Structure

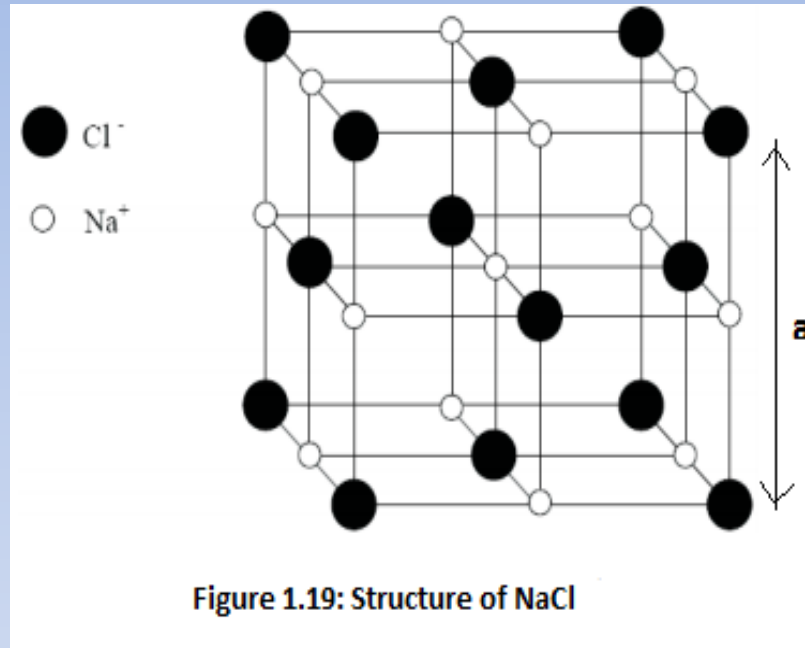

Rock salt (NaCl) structure type is AX, anion packing is fcc, here the cation number is 6, anion is 6. A basis consist one Na and one Cl.

position of Cl and Na atoms are:

Cl :  $0, 0, 0$ ;  $1/2, 1/2, 0$ ;  $1/2, 0, 1/2$ ;  $0, 1/2, 1/2$ ;  
Na :  $1/2, 1/2, 1/2$ ;  $0, 0, 1/2$ ;  $0, 1/2, 1/2$ ;  $1/2, 0, 0$

The coordinate number of each Na and Cl atom in this structure is 6.

Other examples of NaCl (AX) type structure are KBr, KCl, MgO, AgBr.

# 10.2 Cesium Chloride (CsCl) Structure

- Cesium chloride (CsCl) structure type is AX at anion packing is body centered cubic.
- two primitive cells in a cubic unit cell. each unit cell has two molecule (basis) of CsCl.
- Positions of Cl ion is at  $(0, 0, 0)$  and Cs ion is at  $(1/2, 1/2, 1/2)$ .
- The Cs is situated at body center and 8 Cl ions at the corner of unit cell. Similarly if we extend the unit cell we can see a Cl ion is surrounded by 8 Cs ions. Thus the coordinate number of CsCl is 8.
- The other examples of CsCl type structure are RbCl, LiHg etc.
-

● = Cs<sup>+</sup> at (1/2,1/2,1/2)

● = Cl<sup>-</sup> at (0,0,0)

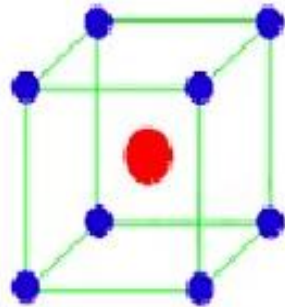

Unit cell of CsCl  
showing Cs<sup>+</sup> ion surrounded  
by 8 Cl<sup>-</sup> ions

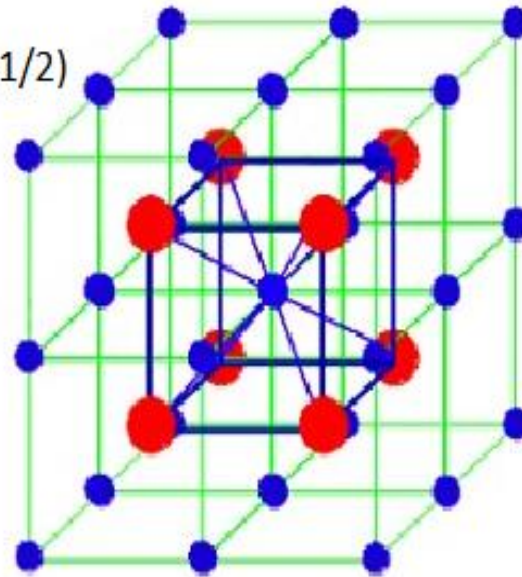

Extended unit cells of CsCl  
showing Cl<sup>-</sup> ion surrounded by 8 Cs<sup>+</sup> ions

Figure 1.20: CsCl Structure

## 10.3 Diamond Structure

- The diamond structure is face centered cubic with four additional atoms in the body diagonals. Out of four additional atoms, two atoms are placed at  $\frac{3}{4}$  length of first and second diagonal, remaining two atoms are placed at  $\frac{1}{4}$  lengths of 3<sup>rd</sup> and 4<sup>th</sup> body diagonals
- Total number of C atoms is 18.
- The whole appearance seems complicated thus for simplicity, we draw the projection of atoms on a plane (say XY plane) as shown in second figure.
- In XY plane, only five atoms are at the face (base of cube) ABCD in actual and other atoms are projections of atom near to face.
- Points E, G, M, K show the projection of atoms at vertical faces of cube and z coordinate of actual position of these atoms are  $\frac{1}{2}$  as shown in figure. We write only z coordinates of projected atom explicitly. Now point F,H,J,L shows the projection of atoms situated at 4 body diagonals and z coordinates of these atoms are  $\frac{1}{2}, \frac{3}{2}, \frac{1}{2}, \frac{3}{2}$ .
- The coordination number (number of nearest neighbours) is 4 and each group of 4 C atoms make a tetrahedral bond arrangement.
- The packing fraction of diamond structure is 0.34, considerably smaller than fcc structure (PF 0.74) and shows relatively empty space in the crystal.

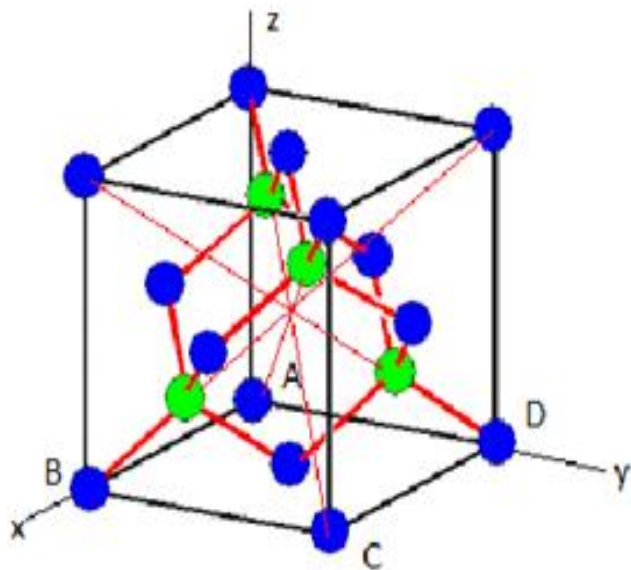

Figure 1.21: Dimond Structure

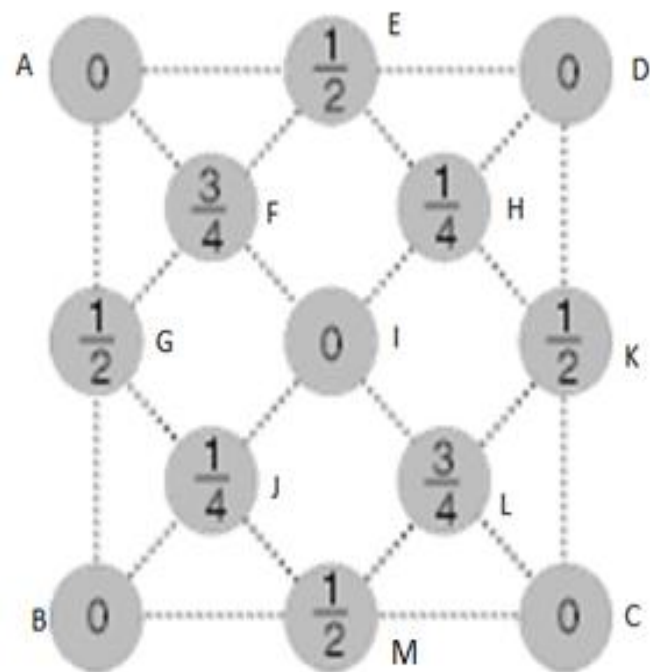
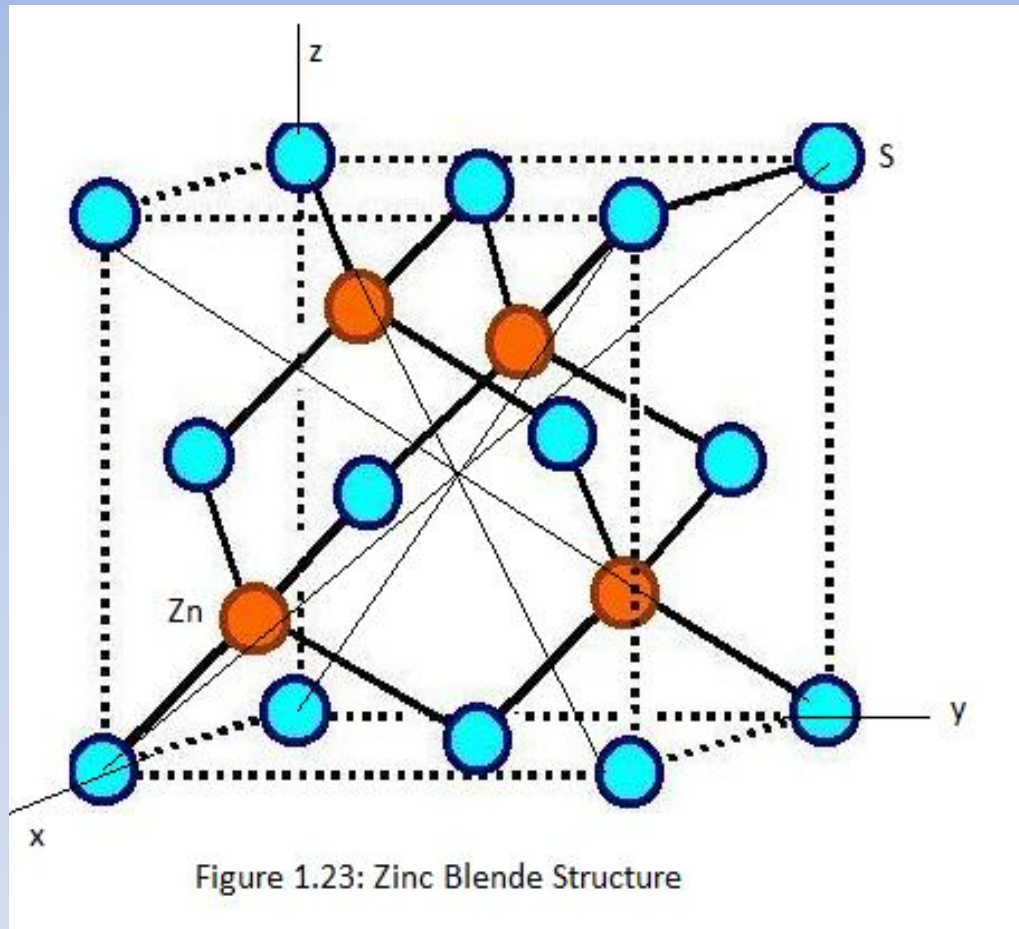

Figure 1.22: Projection on atoms on face ABCD

## 10.4 Zinc Sulfide (Zinc Blende) Structure

- Cubic zinc blende (ZnS) crystal structure is similar to diamond structure the only difference is that the four diagonal atoms are of different type.
- ZnS structure becomes diamond structure if all the diagonal atoms and fcc atoms are same type.
- In figure, circles represent one type of atoms (say Zn atoms) and dark circles show another types of atoms (say S atoms).
- ZnS structure is a prototype and many other compound form ZnS structure as ZnO, GaAs, SiC, BN etc.



## 10.5 Hexagonal close packed (hcp) Structure

- HCP are generally found in monoatomic crystal structure as metals.
- In hcp consider a layer of similar atoms say A, in which each atom is surrounded by six atoms are arranged on the plane of paper as shown in figure. Now another layer of atoms of type B is placed on the paper just above the layer A such as each atoms of type is fitted on the depressions formed by the atoms of layer A. A third layer of atoms of atoms of A type is again placed on the layer B in same manner. Thus the repetition of layers as ABABABAB.....one upon one we get hpc structure.
- The three dimensional figure, six atoms of one type (A type) are arranged at six corners of base hexagon and Six same atoms of A type are placed just upon the top of hexagon at height (distance)  $c$ .
- These two hexagons (base and top) form a unit cell.
- Now just between these two hexagons three atoms of type B are situated (at height  $c/2$ ), as shown in figure 1.25.



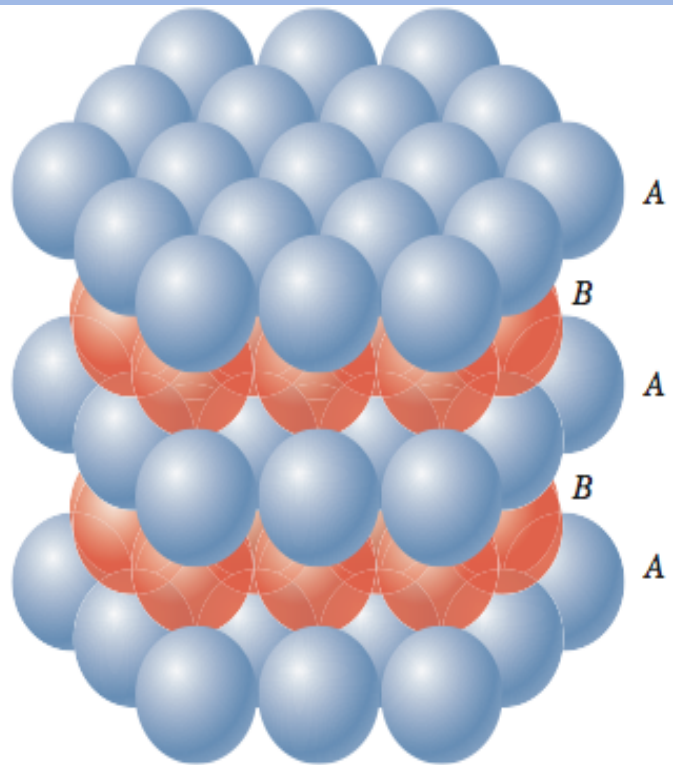

Figure 1.24: Layers of A, B types atoms in hcp

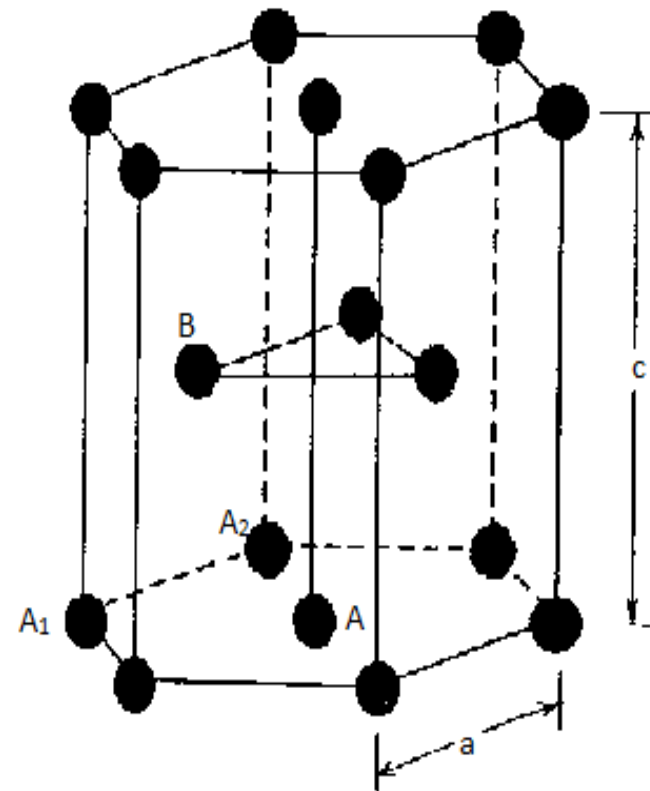

Figure 1.25 : Unit cell of hcp

# Parameters

- The effective number of atoms in a unit cell is  $12 \times 1/6 + 2 \times 1/2 + 3 = 6$ .
- The first term arises as the 12 corners of base and top hexagons contain 12 atoms and each corner atom shared by 6 neighbor hexagons. Thus these atoms contribute  $12 \times 1/6$ . Similarly second term arises as center of top and bottom hexagons, have 2 atoms which are shared by 2 hexagons thus it contributes  $2 \times 1/2$ . In the third term, 3 atoms (may be type B) are fully inside the unit cell between top and base hexagon thus it contributes 3 in the unit cell.
- Thus total 6 atoms are in a unit cell of hcp. If  $a$  is interatomic distance in the layer of hexagon i.e. side length of hexagon, and  $c$  is the height then we can calculate the ratio  $c/a$  which is a standard parameter for hcp structure and calculated as 1.633.

$$\text{Packing fraction (PF)} = \frac{v}{V} = 6 \times \frac{\frac{4}{3}\pi r^3}{6 \times \frac{\sqrt{3}}{4} a^2 \times c} = 0.74$$

- coordinate number CN (number of nearest neighbours) is 12
- CN and PF is same for hcp and fcc crystals. The hcp structure is also shown by Cd, Mg, Ti, Zn crystals.

# 11 Wigner Seitz cell

- There are several ways to choose a primitive cell or unit cell in a crystal.
- A convenient way of choosing the unit cell is the area covered by perpendicular bisectors of lines joining the nearest neighbours. In 3D the smallest volume enclosed in this way is called Wigner Seitz cell.
- Wigner Seitz cell is special type of unit cell, which describes the symmetry of cell. A Wigner–Seitz cell is an example of a primitive cell, which is a unit cell containing exactly one lattice point

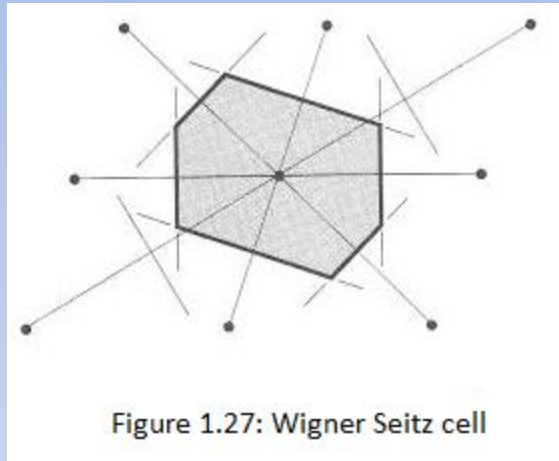

Figure 1.27: Wigner Seitz cell

# 12. Quasi Crystal

- In terms of symmetry, crystalline solids have 2,3,4,6 fold and translational symmetry.
- Previously during the development of crystallography it was assumed that 5, 7,8 fold symmetry are not possible but later on, it was observed there are some crystal with yours 5,7,8 fold symmetries and are called forbidden symmetry.
- Such crystals are called quasi crystals.
- Numbers of solids like platonic solids as shown in figure, exhibit fivefold symmetry.
- two platonic solids out of six, named Dodecahedron and Icosahedron show five fold symmetry.
- Another example of fivefold symmetry is burgman cluster in which a complex unit cell is formed by total 90 atoms out of which 60 carbon atom and 20 Zn-Mg atom.

# 13 Liquid Crystal

- when solids are heated up, it changes into liquid state but there are some solids, when they are heated, not directly change into liquid state but it goes through a intermediate state and state is called liquid solids.
- This mixed state of solid and liquid has property in between true crystals solid and true liquid.
- Main properties of liquid crystals are as ordered arrangement of particles, optically active, fluidity, viscosity, and surface tension.
- Liquid crystals have state which flow like a liquid but have ordered arrangement of atoms.
- In, 1888, Frederick Reinifzer an Austrian Botanists discovered first liquid crystal Cholesteryl benzoate used for hair color.
- **Uses of liquid crystals:**
  - 1. used in display of electrical device known as LCD.
  - 2. used as temperature sensor in thermometers.
  - 3. Used in medical sciences for locating blockage in veins, arteries, infections and tumors by skin thermograph.

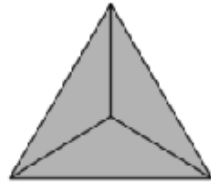

**Tetrahedron**

4 faces  
4 vertices

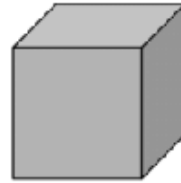

**Cube**

6 faces  
8 vertices

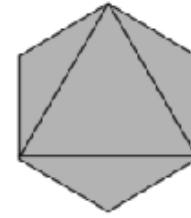

**Octahedron**

8 faces  
6 vertices

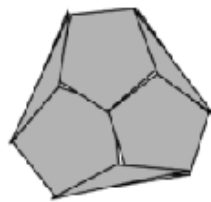

**Dodecahedron**

12 faces  
20 vertices

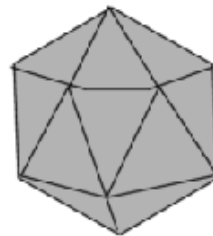

**Icosahedron**

20 faces  
12 vertices

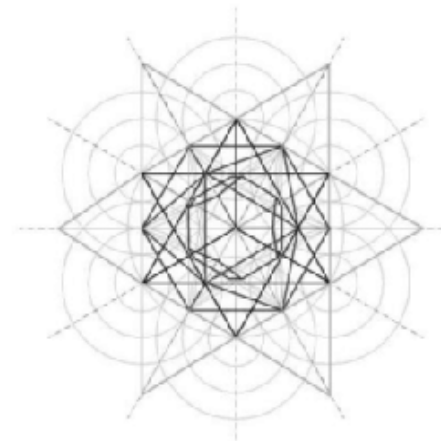

**Nested Platonic  
solids**

Figure 1.28 Platonic Solids